

Automatic Wall-mounted Soap Dispenser Behind Mirror SLZN 84A

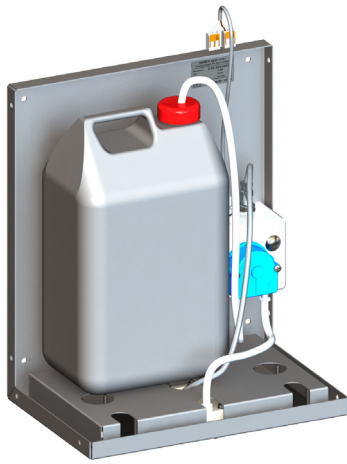

SLZN 84A

*Illustrative photo - container for soap is not included

Characteristics

- automatic wall-mounted soap dispenser behind mirror
- mounting behind mirror
- easy soap refilling
- soap economy
- one dose of soap is flowing as hands are in the active range under the mirror (can be set in range 1,3 - 13 s), standard 2,6 s
- use in the public sector, container for soap 5 l
- parameters adjustment using by the remote control SLD 03

Dimensions

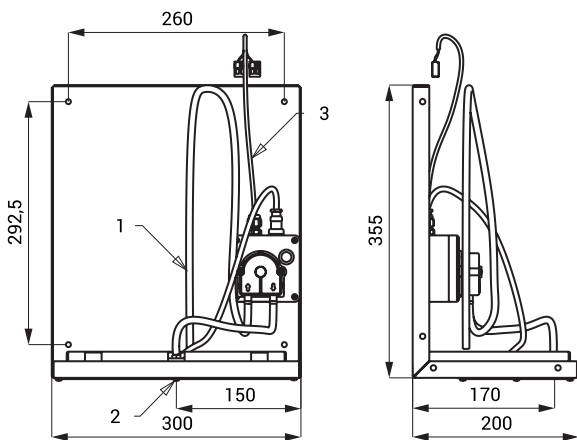

- 1 - soap supply
2 - spout
3 - power supply 24 V DC

Technical Specification

Dimensions	355 x 200 x 300 mm
Operating voltage	24 V DC
Power input	3 W
Active range	0,14 - 0,2 m
Recommended soap viscosity	10 mPa - 5000 mPa

(don't use chemical solvents and disinfection)

Supply Specification

SLZN 84A - Supply No. 85840 stainless steel mounting holder with soap dispenser and electronics, inlet hoses, pump for liquid soap

Recommended Accessories

SLZ 01Y	- Supply No. 05012	power supply 24 V DC for operating of max. 10 pcs. of soap dispensers
SLZ 01Z	- Supply No. 05011	power supply 24 V DC for operating of max. 20 pcs. of soap dispensers
SLZ 04Y	- Supply No. 05042	power supply 24 V DC for DIN rail, for operating of max. 10 pcs. of soap dispensers
SLZ 04Z	- Supply No. 05041	power supply 24 V DC for DIN rail, for operating of max. 20 pcs. of soap dispensers
SLZ 04X	- Supply No. 10049	power supply 24 V DC for DIN rail, for operating of max. 30 pcs. of soap dispensers
SLZ 06	- Supply No. 05060	power supply 24 V DC pro max. 1 pc. of soap dispenser
SLD 03	- Supply No. 07030	remote control for an adjustment of parameters