

# Automatic Stainless Steel Wall-mounted Central Soap Dispensers SLZN 83E2 - 83E6



SLZN 83E

## Characteristics

- easy soap refilling
- soap economy
- one dose of soap is flowing as hands are in the active range of the sensor (can be set in range 1,3 - 13 s), standard 2,6 s
- possibility of delivery 2 - 6 pcs. of soap dispensers with central unit made to order
- use in the public sector; container for soap 6 l
- parameters adjustment using by the remote control SLD 03

## Installation Drawing

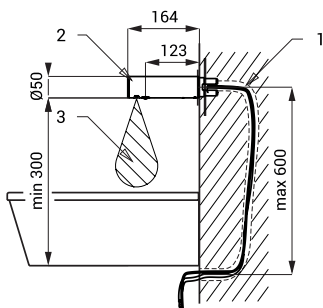

- 1 - soap supply and power supply 24 V DC in a protective tube  
2 - spout with electronics  
3 - active range

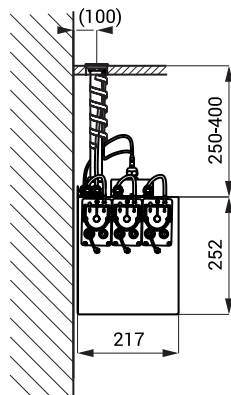
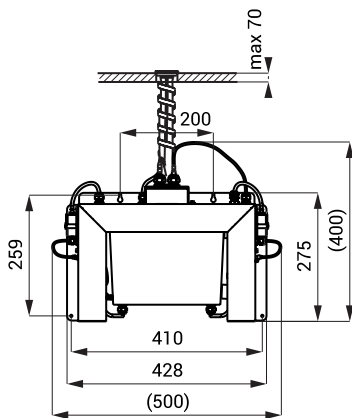

## Technical Specification

<b>Operating voltage</b>	24 V DC
<b>Power input</b>	
SLZN 83E2	5 W
SLZN 83E3	7 W
SLZN 83E4	9 W
SLZN 83E5	12 W
SLZN 83E6	14 W
<b>Active range</b>	0,11 - 0,15 m
<b>Recommended soap viscosity</b>	10 mPa - 5000 mPa
(don't use chemical solvents and disinfection)	

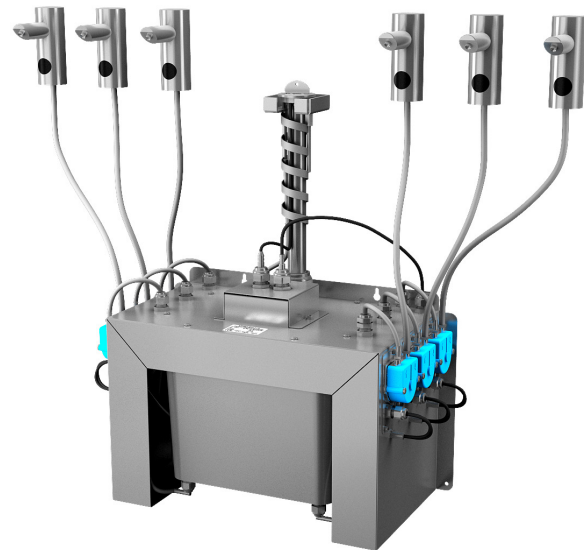

## Supply Specification

SLZN 83E2 - Supply No. 85832

stainless steel spout with electronics (2 pcs.), grip plate, inlet hoses and cables in a protective tube 80 cm, central soap dispenser with peristaltic pumps for liquid soap and soap container 6 l, power supply SLZ 01Y, remote control SLD 03

SLZN 83E3 - Supply No. 85833

stainless steel spout with electronics (3 pcs.), grip plate, inlet hoses and cables in a protective tube 80 cm, central soap dispenser with peristaltic pumps for liquid soap and soap container 6 l, power supply SLZ 01Y, remote control SLD 03

SLZN 83E4 - Supply No. 85834

stainless steel spout with electronics (4 pcs.), grip plate, inlet hose and cables in a protective tube 80 cm, central soap dispenser with peristaltic pumps for liquid soap and soap container 6 l, power supply SLZ 01Y, remote control SLD 03

SLZN 83E5 - Supply No. 85835

stainless steel spout with electronics (5 pcs.), grip plate, inlet hoses and cables in a protective tube 80 cm, central soap dispenser with peristaltic pumps for liquid soap and soap container 6 l, power supply SLZ 01Y, remote control SLD 03

SLZN 83E6 - Supply No. 85836

stainless steel spout with electronics (6 pcs.), grip plate, inlet hoses and cables in a protective tube 80 cm, central soap dispenser with peristaltic pumps for liquid soap and soap container 6 l, power supply SLZ 01Y, remote control SLD 03