

Stainless Steel Piezo Washing Trough SLUN 50PA

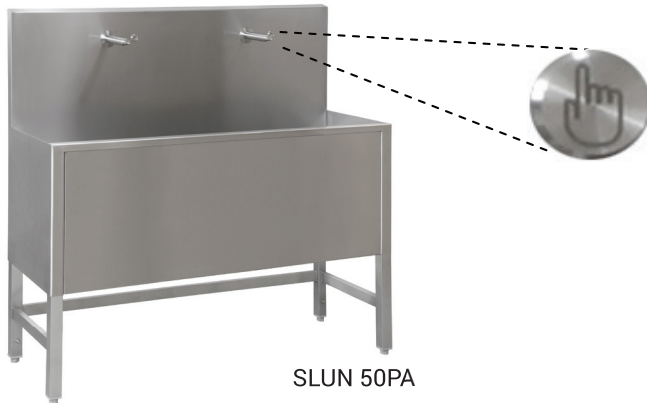

SLUN 50PA

Characteristics



- economical aerator, rate of flow 6 l/min
- hygienic flush
- vandal-proof
- suitable for a prison
- with a complete sheathing
- stainless steel floor standing washing trough with integrated piezo electronics
- vandal-proof stainless steel spouts
- water flows after soft push of the piezo button
- water stops flowing after adjustable flowing time (can be set in 2 - 62 s), standard 10 s
- water could be stopped by follow-up soft push of piezo button
- parameter adjustment using by the remote control SLD 04
- different lengths could be made to order
- material AISI - 304
- could be made to order from stainless steel AISI - 316L
- brushed finish

Dimensions

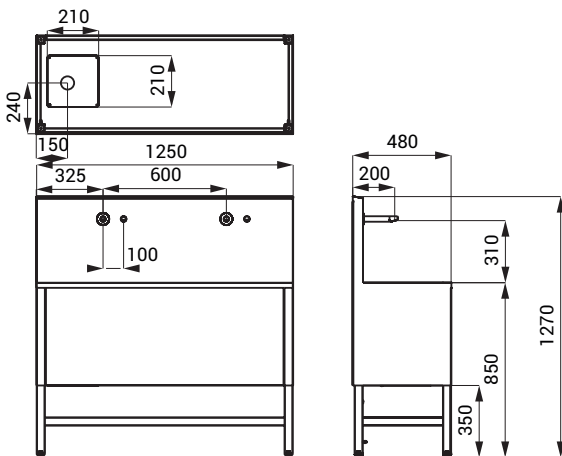

Technical Specification

Operating voltage	24 V DC
Power input	14 W
Recommended flow pressure	0,1 - 0,6 MPa
Rate of flow	6 l/min. (inf. data)
Water inlet	male thread G 1/2"

Supply Specification

SLUN 50PA - Supply No. 93505 stainless steel washing trough with piezo electronics (2 pcs.), spout (2 pcs.), electromagnetic valve (2 pcs.), connecting hoses, angle valve with filter (2 pcs.), siphon

Recommended Accessories

SLZ 01Y - Supply No. 05012	power supply 24 V DC for operating of max. 2 pcs. of washing troughs
SLZ 01Z - Supply No. 05011	power supply 24 V DC for operating of max. 4 pcs. of washing troughs
SLZ 04Y - Supply No. 05042	power supply 24 V DC for DIN rail, for operating of max. 2 pcs. of washing troughs
SLZ 04Z - Supply No. 05041	power supply 24 V DC for DIN rail, for operating of max. 4 pcs. of washing troughs
SLZ 04X - Supply No. 10049	power supply 24 V DC for DIN rail, for operating of max. 7 pcs. of washing troughs
SLD 04 - Supply No. 07040	remote control for an adjustment of parameters
SLA 56A - Supply No. 06560	economical aerator 3,8 l/min
SLA 56B - Supply No. 06561	economical aerator 1,9 l/min