

Automatic Washbasin Mixer SLU 18

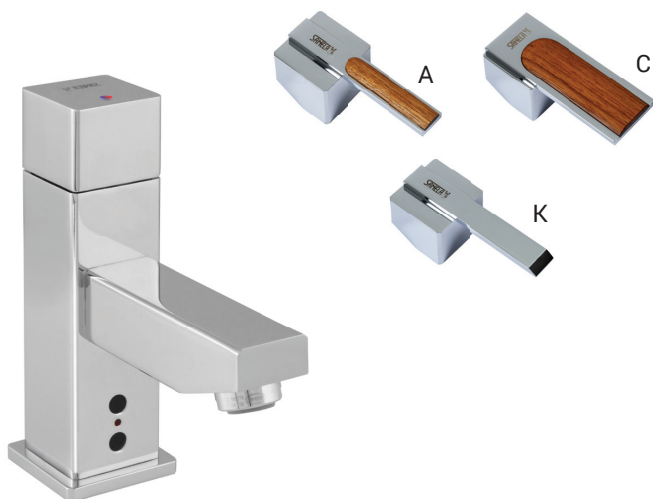

Characteristics



- economic aerator, rate of flow 6 l/min
- hygienic flush
- is destined for cold and hot water, temperature is regulated by mixer
- index „A“, „C“, „K“ - design of mixer
- water is flowing as long as hands are in the active range
- water stops flowing after removal of hands from the active range of sensor after adjustable time delay (can be set in range 0,25 – 7,75 s)
- function of automatic water stop after 5 minut of continuous flow
- monitoring of battery capacity (for models with index B)
- START/STOP program
- parameter adjustment using by the remote control SLD 03

Dimensions

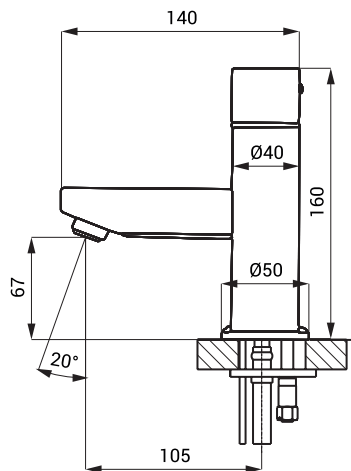

Technical Specification

Operating voltage

- SLU 18, 18A, 18C, 18K 24 V DC
- SLU 18B, 18AB, 18CB, 18KB 9 V

Power input

- operating by 24 V DC 14 W
- operating by 9 V 11 W

Battery life

- lithium 9V, type U9VL approx. 2 years (100 uses per day)

Active range

- standard 0,13 - 0,19 m
- START/STOP program 0,05 - 0,15 m

Recommended flow pressure

- 0,1 - 0,6 MPa

Rate of flow

- 6 l/min. (inf. data)

Water inlet

- male thread G 1/2"

Supply Specification

SLU 18	-	Supply No. 03180	faucet with mixer and electronics, holder of electronics, electromagnetic valve
SLU 18A	-	Supply No. 43184	(2 pcs.), connecting hoses, angle valve with filter and check valve (2 pcs.),
SLU 18C	-	Supply No. 43182	lithium battery SLA 09 with battery case (for models with index B)
SLU 18K	-	Supply No. 13187	
SLU 18B	-	Supply No. 03185	
SLU 18AB	-	Supply No. 43185	
SLU 18CB	-	Supply No. 43183	
SLU 18KB	-	Supply No. 43181	

Recommended Accessories

SLZ 01Y	-	Supply No. 05012	power supply 24 V DC for operating of max. 2 pcs. of washbasin taps
SLZ 01Z	-	Supply No. 05011	power supply 24 V DC for operating of max. 4 pcs. of washbasin taps
SLZ 04Y	-	Supply No. 05042	power supply 24 V DC for DIN rail, for operating of max. 2 pcs. of washbasin taps
SLZ 04Z	-	Supply No. 05041	power supply 24 V DC for DIN rail, for operating of max. 4 pcs. of washbasin taps
SLZ 04X	-	Supply No. 10049	power supply 24 V DC for DIN rail, for operating of max. 7 pcs. of washbasin taps
SLD 03	-	Supply No. 07030	remote control for an adjustment of parameters
SLA 09	-	Supply No. 06090	lithium battery 9V/1200 mAh, type U9VL (for models with index B)