

Automatic Wall-mounted Soap Dispenser Behind Mirror SLZN 84A



Characteristics

- automatic wall-mounted soap dispenser behind mirror
- inner plastic container ABS
- mounting behind mirror
- easy soap refilling
- soap economy
- one dose of soap is flowing as hands are in the active range under the mirror (can be set in range 1,3 - 13 s), standard 2,6 s
- use in the public sector, container for soap 5 l
- parameters adjustment using by the remote control SLD 03
- material stainless steel AISI 304 (1.4301)

Dimensions

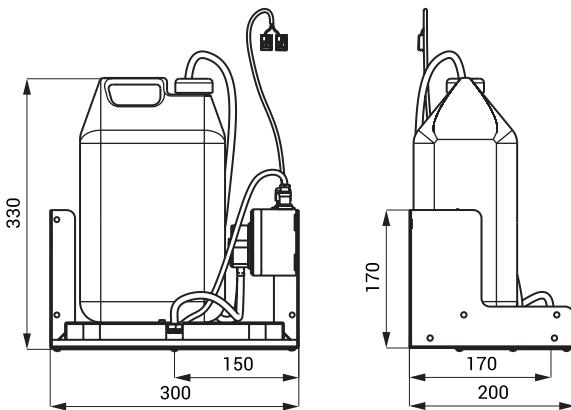

Technical Specification

Dimensions	330 x 200 x 300 mm
Weight	1,6 kg
Thickness of stainless steel material	1 mm
Volume	5 l
Operating voltage	24 V DC
Power input	3 W
Active range	0,14 - 0,2 m
Recommended soap viscosity	10 mPa*s - 5000 mPa*s
(don't use chemical solvents and disinfection)	

Supply Specification

SLZN 84A - Supply No. 85840 stainless steel mounting holder with soap dispenser and electronics, inlet hoses, pump for liquid soap, container for soap 5 l

Recommended Accessories

SLZ 01Y - Supply No. 05012	power supply 24 V DC for operating of max. 10 pcs. of soap dispensers
SLZ 01Z - Supply No. 05011	power supply 24 V DC for operating of max. 20 pcs. of soap dispensers
SLZ 04Y - Supply No. 05042	power supply 24 V DC for DIN rail, for operating of max. 10 pcs. of soap dispensers
SLZ 04Z - Supply No. 05041	power supply 24 V DC for DIN rail, for operating of max. 20 pcs. of soap dispensers
SLZ 04X - Supply No. 10049	power supply 24 V DC for DIN rail, for operating of max. 30 pcs. of soap dispensers
SLZ 06 - Supply No. 05060	power supply 24 V DC pro max. 1 pc. of soap dispenser
SLD 03 - Supply No. 07030	remote control for an adjustment of parameters