

# Automatic Washbasin Mixer SLU 76



## Characteristics



- economical aerator, rate of flow 6 l/min
- hygienic flush
- possibility of water temperature adjustment by mixer and follow-up plug by cover
- electromagnet valve is in the tap body
- is destined for cold and hot water, temperature is regulated by mixer
- water is flowing as long as hands are in the active range
- water stops flowing after removal of hands from the active range of sensor after adjustable time delay (can be set in range 0,25 – 7,75 s)
- function of automatic water stop after 5 minut of continuous flow
- monitoring of battery capacity (for models with index B)
- START/STOP program
- parameter adjustment using by the remote control SLD 03

## Dimensions

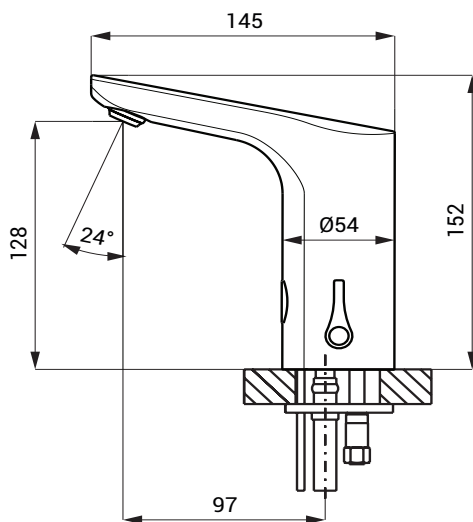

## Technical Specification

### Operating voltage

- SLU 76 24 V DC
- SLU 76B 6 V

### Power input

- operating by 24 V DC 2 W
- operating by 6 V 2 W

### Battery life

- 4 pcs. AA alkaline batteries approx. 2 years (100 uses per day)
- AA, 1,5 V, 2700 mAh

### Active range

- standard 0,13 - 0,19 m
- START/STOP program 0,05 - 0,15 m

### Recommended flow pressure

- 0,1 - 0,6 MPa

### Rate of flow

- 6 l/min. (inf. data)

### Water inlet

- male thread G 1/2"

## Supply Specification

- SLU 76 - Supply No. 03760 faucet with mixer, electronics and electromagnet valve, connecting hoses, angle valve with filter and check valve (2 pcs.), cover for temperature mixer, 4 pcs. AA alkaline batteries 1,5 V, 2700 mAh with battery case (SLU 76B)
- SLU 76B - Supply No. 03765

## Recommended Accessories

- SLZ 01Y - Supply No. 05012 power supply 24 V DC for operating of max. 10 pcs. of washbasin taps
- SLZ 01Z - Supply No. 05011 power supply 24 V DC for operating of max. 20 pcs. of washbasin taps
- SLZ 04Y - Supply No. 05042 power supply 24 V DC for DIN rail, for operating of max. 10 pcs. of washbasin taps
- SLZ 04Z - Supply No. 05041 power supply 24 V DC for DIN rail, for operating of max. 20 pcs. of washbasin taps
- SLZ 04X - Supply No. 10049 power supply 24 V DC for DIN rail, for operating of max. 30 pcs. of washbasin taps
- SLD 03 - Supply No. 07030 remote control for an adjustment of parameters
- SLA 36 - Supply No. 06360 set of 4 pcs. alkaline batteries AA, 1,5 V, 2700 mAh (for models with index B)
- SLA 57A - Supply No. 06570 economical aerator 3,8 l/min
- SLA 57B - Supply No. 06571 economical aerator 1,9 l/min