

Stainless Steel Floor-Standing Urinal Mangers SLPN 02Z, SLPN 03Z, SLPN 04Z, SLPN 05Z



SLPN 03Z

Characteristics: NEW

- **vandal-proof**
- stainless steel floor-standing (built-in) urinal mangers
- mangers are delivered in the lengths 600, 1200, 1800 and 2400 mm
- pipe flushing in the upper part of the manger
- ruff around the bottom part for connection to hydro-isolation
- removable cover of flushing pipe (4 nuts on the edges of the manger)
- **different lengths could be made to order**
- material CrNi 18/10 (AISI-304)
- brushed finish

Technical Specification:

Recommended flow pressure	0,1 - 0,6 MPa
Rate of flow	12 l/min. (inf. data)
Water inlet	male thread G 1/2"
Stainless steel thickness	1,5 mm

Dimensions:

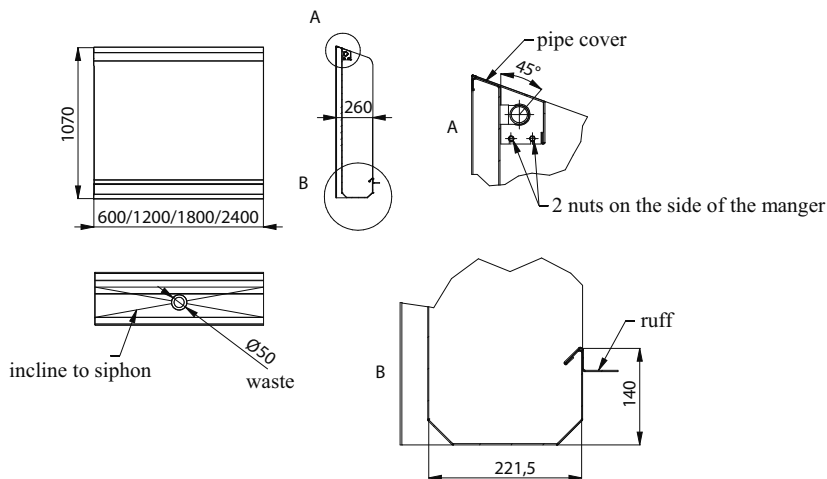

Supply Specification:

- SLPN 02Z – **supply No. 91026** stainless steel urinal manger 600 mm; flushing pipe; mounting set; siphon
- SLPN 03Z – **supply No. 91036** stainless steel urinal manger 1200 mm; flushing pipe; mounting set; siphon
- SLPN 04Z – **supply No. 91046** stainless steel urinal manger 1800 mm; flushing pipe; mounting set; siphon
- SLPN 05Z – **supply No. 91056** stainless steel urinal manger 2400 mm; flushing pipe; mounting set; siphon

Recommended Accessories:

- SLD 04 – **supply No. 07040** universal remote control for an adjustment of parameters (see page 115)
- SLP 01Z – **supply No. 01011** time-controlled flushing unit (see page 43)

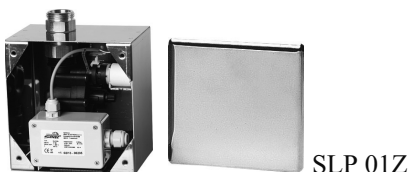

SLP 01Z