

Stainless Steel/HPL Shower Seat, Wall Hung, Folding SLZM 06N



SLZM 06N

Characteristics



- for disabled and persons with limited mobility
- stainless steel/HPL shower seat, wall hung, folding
- weight load resistance up to 272 kg
- dimensions 560 x 395 mm
- brushed stainless steel
- seat white, black trim, material HPL

Dimensions

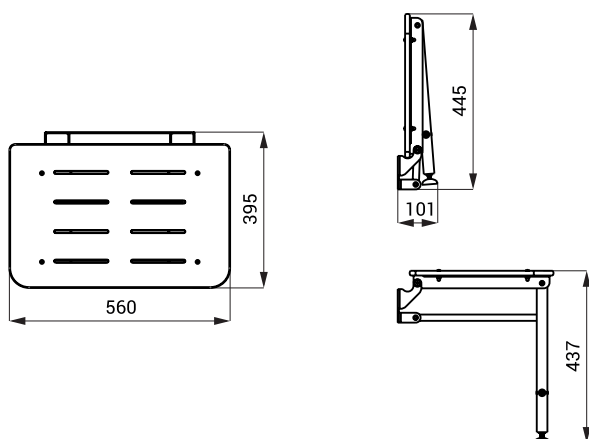

Supply Specification

SLZM 06N - Supply No. 49061 stainless steel/HPL shower seat